



Performance and productivity

- Best load capacities
- Self-locking rear axle differential (limited slip 45%)

Powerful and robust

- High strength monoblock chassis
- Hydrostatic transmission and electronic inching pedal for controlled advancement

Comfort and ergonomomy

- Anti-tipping device with hazardous movement block
- High safety cab
- Smart control 4 in 1 joystick



HTL 6508



TELEHANDLER

Haulotte

GROUP

PERFORMANCES

Maximum lift capacity	6500 kg
Lift capacity to full height	4200 kg
Lift capacity at full reach	2000 kg
Maximum fork height	7.7 m
Reach at maximum fork height	0.6 m
Maximum forward reach	4.2 m



DIMENSIONS

A Length	5.05 m
B Width	2.39 m
C Height	2.5 m
D Wheelbase	2.8 m
E Ground clearance	40 cm
F Track width	1.92 m
G Cab width	0.94 m
Reach at maximum fork height	0.6 m
Lower rotation of forks	144 °
Turning radius (outside wheels)	4.4 m
Weight with forks	11260 kg
Tyres type	18x22.5"



ENGINE

TIER IV i

Engine model	FPT Interim TIER IV
Engine Capacity	4500 cm3
Engine power output	96kW @ 2200rpm
Engine torque	590Nm @ 1500rpm
Transmission type	Hydrostatic
Fuel tank	125 l
Engine oil	11.5 l

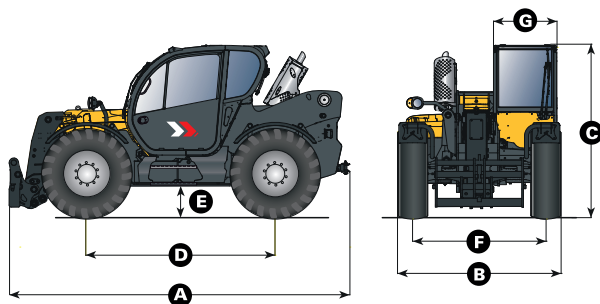

STANDARD EQUIPMENT

- Colour LCD display
- Hydrostatic transmission
- 4 wheel drive and steer
- Simultaneous and proportional controls for boom / telescopic arm / excavation and accessories movements
- Safety valves on hydraulic jacks
- Auxiliary hydraulic system
- Anti-tipping device with hazardous movement block
- Soundproof closed cab, ROPS-FOPS approved, with heating

OPTIONS AND ACCESSORIES

- Winches
- Jibs
- Forks
- Buckets
- Air conditioning
- LED light on boom
- Metal windscreen protector (FOPS)
- Tilt corrector
- Reverse fan
- Automatic wheels alignment

